

Merus™ Hybrid Power Quality (HPQ) solution with solar power production

1. Introduction

An automobile gear factory in China had a feeder that was suffering from issues related to poor power quality. Power factor was poor and there were significant harmonic currents in the feeder as well.

A renewable energy system is deployed to provide clean power to the power system of the factory; nevertheless, it aggravates the power quality problem of the supply system.

The power quality measurement was carried out on the site and based on those measurement it was decided to install a new hybrid system to get rid of the power quality problems and fulfill standard requirements.

2. The Merus™ HPQ system

NCS used innovative Merus HPQ solution modules which they integrated in their capacitor bank system.

The Merus™ Hybrid Power Quality solution is a combination of traditional detuned capacitor steps and a modern Merus™ A2-Active Filter using a single control system. This system provides a complete power quality solution that is fully programmable to provide dynamic reactive power compensation and harmonic mitigation. Because the system is controlled with single controller, “hunting” between different reactive power controller is no issue in Merus HPQ applications.

2.1. Technical information

The Merus™ HPQ is a unique and reliable all-in-one solution that provides:

- Power factor correction
- Harmonic mitigation
- Unbalance mitigation

The fundamental correction of reactive power is supplied with capacitor steps. Merus active filter provides stepless reactive power in the middle of the capacitor steps, inductive reactive power, harmonic mitigation and load balancing.

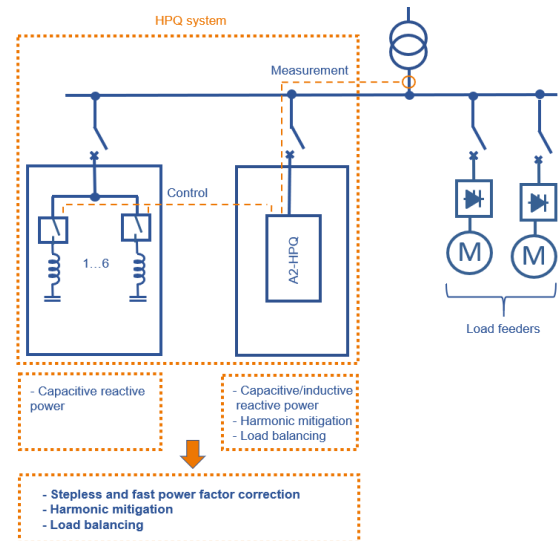

Figure 1 Schematic illustration of the Merus™ HPQ solution

2.2. Advantages of the Merus™ HPQ solution

The advantages of the solution include the following:

- **Reliable all-in-one solution.** Reactive power, harmonic mitigation and unbalance correction in one control system and one HMI
- **Easy to use.** Single control system ensures stable solution, no additional APFR (Auto Power Factor Regulator) is needed
- **Dynamic and stepless response**
- **Increased lifetime of the capacitors.** Harmonic mitigation decreases harmonic currents going in the capacitor steps
- **Small footprint**

3. Installation and equipment

Two Merus™ HPQ solutions were installed in the location. One of the systems is covered in this paper.

3.1. SLD

The illustrative picture of the single line diagram is presented below. There was also solar power production connected in this feeder which can produce power to the feeder. Fig. 3 depicts the active power flow measured at the system main feeder.

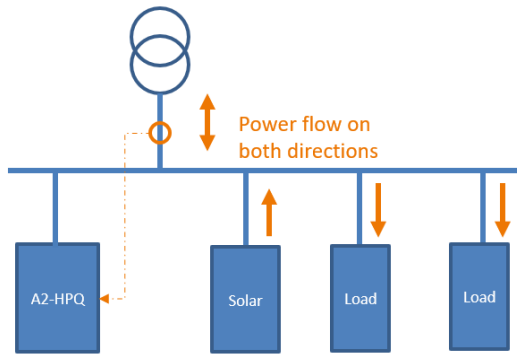

Figure 2 Simplified SLD of the installation

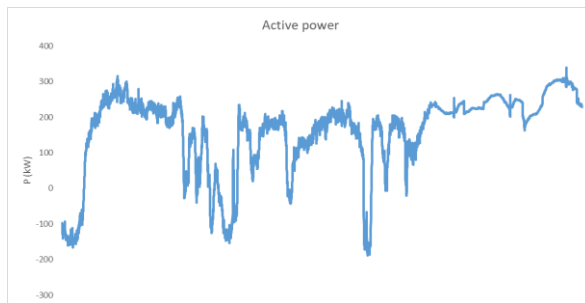

Figure 3 Active power on the feeder

3.2. HMI

The Merus™ HPQ is equipped with a modern Human Machine Interface (HMI). The HMI panel allows the user to program various modes and parameters and view the monitoring values such as waveforms from both network and load side. Furthermore, the capacitor bank status is also available on the HMI.

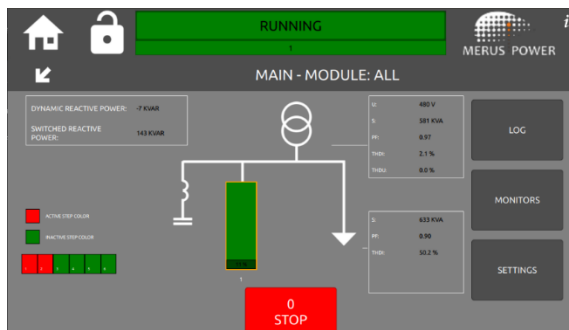

Figure 4 The HMI main screen

4. System and setting information

The load in this feeder consists grinding machines, roller machines, air conditioners and solar production. These loads are often equipped with Variable Speed Drives (VSD). These drives usually produce 5th, 7th, 11th and 13th harmonics and inductive reactive power.

As a solution the installed equipment was:

- 100-A Merus™ A2-HPQ-module + 6 sets of contactor controlled 120 kvar detuned capacitors steps

4.1. The feeder state before improvement

When the Merus™ HPQ was connected into the network, the system HMI displayed monitoring values of the connected network. The average data from the feeder was gathered:

- 3-phase PF: **0.4_{ind}**
- Average voltage: **395 VAC.**
- THDi: **40 %**

The design targets

The goal was to:

- Reduce THDi: **<10%**
- Increase Power Factor: **0.95**

4.2. System settings

Based on the analysis of the recorded data, the Merus™ HPQ system was programmed with the below settings:

- Target power factor: **0.95_{ind.}**
- Harmonic mitigation on:
 - **3rd, 5th, 7th, 11th and 13th**
- Unbalance mitigation was also applied although there was no significant current unbalance at the installation time

The compensation system does not need additional action or setting to handle the bidirectional active power flow at the system main feeder, the system can automatically detect the power flow and work properly.

5. Installation pictures



Figure 5 The Merus™ HPQ solution installation



Figure 6 The HMI view

6. Measurement data

The system was monitored with an external power quality analyzer to validate the performance. Snapshots and a longer time recording were made with compensation operating. The measurement was carried out at the secondary of the transformer.

6.1. Snapshots

The graphs in Fig. 7 and Fig. 8 show the improvement of current waveforms without and with the system operation, respectively.

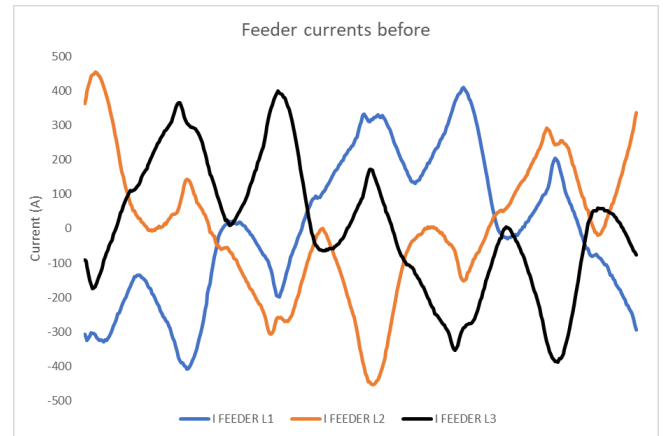

Figure 7 Feeder currents before

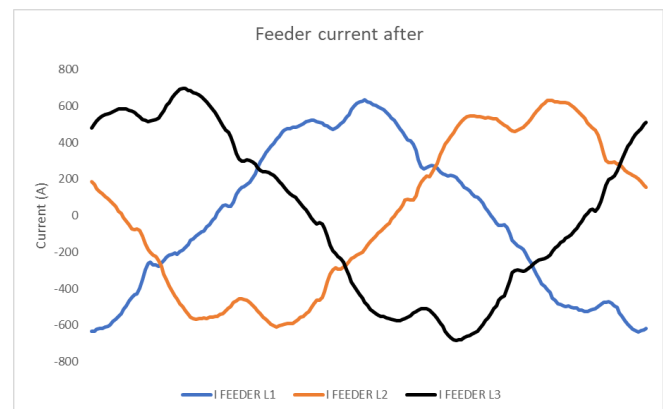

Figure 8 Feeder currents after

6.2. Trend charts

The trend chart data was recorded with Fluke 1760 power quality meter. In the beginning of the trend the Merus™ HPQ system was off and then turned on.

- The data was recorded with 1s interval
- The length of recording was 1 hours

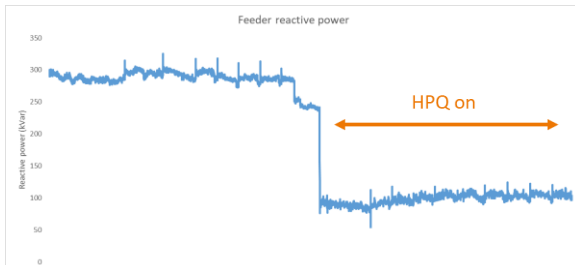

Figure 9 Reactive power on the feeder

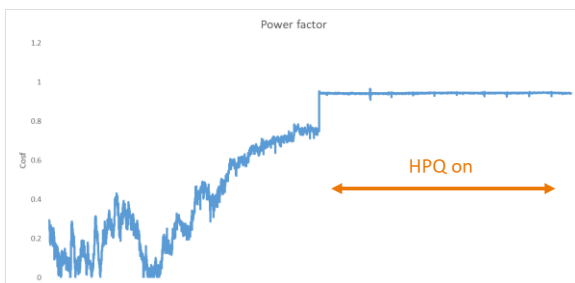

Figure 10 Three phase power factor

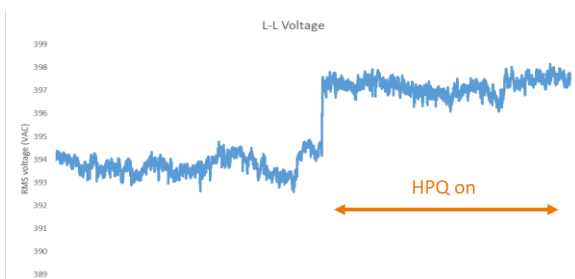

Figure 11 System voltage

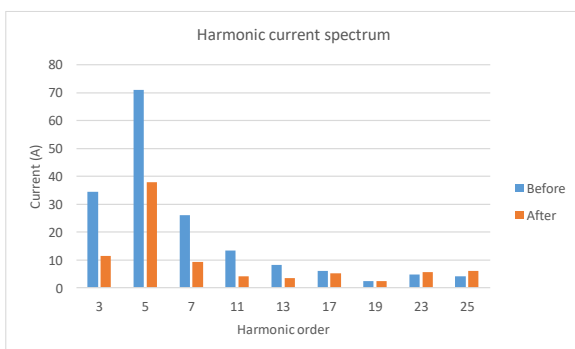

Figure 12 Harmonic current spectrum

The power factor stays in steady 0.95_{ind.}, and the feeder voltage was increased. Lower amount of harmonics were going in the feeder after installation, as shown in Fig. 12. The harmonic currents were not mitigated completely owing to the insufficient installation capacity in this application.

6.3. The feeder's state after compensation

After the compensation was installed the preliminary power quality goal was met.

- PF: **0.95_{ind}**
- THD_i: **<10%**.

7. Benefits

- The compensation reduced the reactive power and harmonics in the network.
- Stabilized the system voltage and improved the voltage drop
- By mitigating harmonics the electrical equipment's lifetime was increased.

8. Conclusion

The power quality in the feeder has been improved after the Merus™ HPQ installation: Solution has improved the stability of their electrical system, increased equipment lifetime and made the system compatible with power quality standards. Moreover, Merus™ HPQ compensation system provides an overall power quality solution for the renewable energy system applications.